

# Instructions



## TLASWUP Software Installation Instructions 075-0860-03

This document applies to TLA System Software version 5.1.

### **Warning**

The servicing instructions are for use by qualified personnel only. To avoid personal injury, do not perform any servicing unless you are qualified to do so. Refer to all safety summaries prior to performing service.

**[www.tektronix.com](http://www.tektronix.com)**



075086003

Copyright © Tektronix. All rights reserved. Licensed software products are owned by Tektronix or its subsidiaries or suppliers, and are protected by national copyright laws and international treaty provisions.

Tektronix products are covered by U.S. and foreign patents, issued and pending. Information in this publication supercedes that in all previously published material. Specifications and price change privileges reserved.

TEKTRONIX and TEK are registered trademarks of Tektronix, Inc.

## **Contacting Tektronix**

Tektronix, Inc.  
14200 SW Karl Braun Drive  
P.O. Box 500  
Beaverton, OR 97077  
USA

For product information, sales, service, and technical support:

- In North America, call 1-800-833-9200.
- Worldwide, visit [www.tektronix.com](http://www.tektronix.com) to find contacts in your area.

# General Safety Summary

Review the following safety precautions to avoid injury and prevent damage to this product or any products connected to it.

To avoid potential hazards, use this product only as specified.

*Only qualified personnel should perform service procedures.*

While using this product, you may need to access other parts of a larger system. Read the safety sections of the other component manuals for warnings and cautions related to operating the system.

## To Avoid Fire or Personal Injury

**Use Proper Power Cord.** Use only the power cord specified for this product and certified for the country of use.

**Connect and Disconnect Properly.** Do not connect or disconnect probes or test leads while they are connected to a voltage source.

**Ground the Product.** This product is grounded through the grounding conductor of the power cord. To avoid electric shock, the grounding conductor must be connected to earth ground. Before making connections to the input or output terminals of the product, ensure that the product is properly grounded.

**Observe All Terminal Ratings.** To avoid fire or shock hazard, observe all ratings and markings on the product. Consult the product manual for further ratings information before making connections to the product.

The inputs are not rated for connection to mains or Category II, III, or IV circuits.

Connect the probe reference lead to earth ground only.

**Power Disconnect.** The power cord disconnects the product from the power source. Do not block the power cord; it must remain accessible to the user at all times.

**Do Not Operate Without Covers.** Do not operate this product with covers or panels removed.

**Do Not Operate With Suspected Failures.** If you suspect there is damage to this product, have it inspected by qualified service personnel.

**Avoid Exposed Circuitry.** Do not touch exposed connections and components when power is present.

**Do Not Operate in Wet/Damp Conditions.**

**Do Not Operate in an Explosive Atmosphere.**

**Keep Product Surfaces Clean and Dry.**

**Provide Proper Ventilation.** Refer to the manual’s installation instructions for details on installing the product so it has proper ventilation.

**Terms in this Manual**

These terms may appear in this manual:



---

**WARNING.** *Warning statements identify conditions or practices that could result in injury or loss of life.*

---



---

**CAUTION.** *Caution statements identify conditions or practices that could result in damage to this product or other property.*

---

**Symbols and Terms on the Product**

These terms may appear on the product:

- DANGER indicates an injury hazard immediately accessible as you read the marking.
- WARNING indicates an injury hazard not immediately accessible as you read the marking.
- CAUTION indicates a hazard to property including the product.

The following symbol(s) may appear on the product:

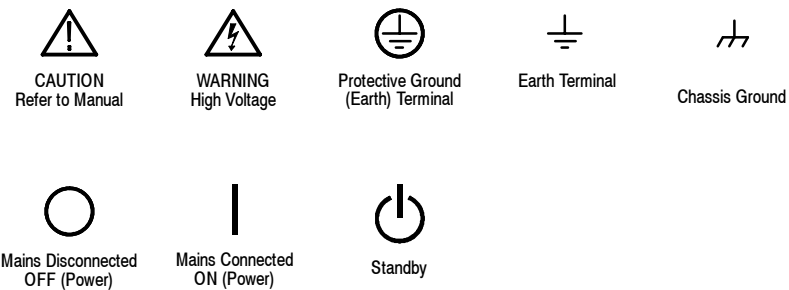

# Service Safety Summary

Only qualified personnel should perform service procedures. Read this *Service Safety Summary* and the *General Safety Summary* before performing any service procedures.

**Do Not Service Alone.** Do not perform internal service or adjustments of this product unless another person capable of rendering first aid and resuscitation is present.

**Disconnect Power.** To avoid electric shock, switch off the instrument power, then disconnect the power cord from the mains power.

**Use Care When Servicing With Power On.** Dangerous voltages or currents may exist in this product. Disconnect power, remove battery (if applicable), and disconnect test leads before removing protective panels, soldering, or replacing components.

To avoid electric shock, do not touch exposed connections.



# TLASWUP Description

The TLASWUP software upgrade kit provides instructions and software to upgrade your Tektronix Logic Analyzer to TLA application software, version 5.1. It also supports the upgrade to Version 1.8 Pattern Generator application software for those instruments with TLA7PG2 Pattern Generator modules. The TLA Application Software V5.1 and higher will only run on TLA instruments with Windows XP Professional or Windows 2000 Professional operating systems purchased from Tektronix. The software will also run on a PC with Microsoft Windows XP Professional or Windows 2000 Professional operating systems.

To prevent personal injury or damage to the instrument, consider the following requirements before attempting service:

- Read the *General Safety Summary* and *Service Safety Summary* found at the beginning of this manual.
- The procedures in this manual should be performed by a qualified service person.

Be sure to follow all warnings, cautions and notes.

This document supports Tektronix modification: 30825

## Instruments

<b>TLA7012 Portable Mainframe</b>	All serial numbers
<b>TLA7016 Benchtop Mainframe</b>	All serial numbers
<b>TLA7PC1 Benchtop Controller</b>	All serial numbers
<b>TLA5000 Series Logic Analyzers</b>	All serial numbers
<b>TLA5000B Series Logic Analyzers</b>	All serial numbers
<b>TLA715 Portable Mainframe</b>	All serial numbers
<b>TLA721 Benchtop Mainframe</b>	All serial numbers

---

**NOTE.** Unless otherwise noted all references to TLA5000 Series Logic Analyzers apply to both TLA5000B and TLA5000 instruments.

---

## TLA System and PC Requirements

- Minimum 10 GB hard drive, 500 MB free space
- 256 MB RAM minimum, 512 MB recommended

## Minimum Tool and Equipment List

No special tools are required to install this software.

## Parts List

**Table 1: Parts list**

<b>Quantity</b>	<b>Part number</b>	<b>Description</b>
1 ea	NS	Tektronix Logic Analyzer Family Application Software V5.1
1 ea	NS	Tektronix Logic Analyzer Family Product Documentation CD
1 ea	NS	Nero OEM Suite CD
1 ea	075-0860-03	TLASWUP Software Upgrade Kit Instructions
1 ea	NS	CheckIt Utilities sticker
1 sheet	NS	Software revision labels
4 ea	NS	Kit labels: TLA7KUP, TLA5KUP, TLA7UP

**NS - Not Saleable**



# Installation Instructions

The following instructions direct you through the process of upgrading the TLA application software on your TLA logic analyzer. These instructions apply only to instruments with TLA Application Software V4.0 or higher. To install the TLA application software on a PC, see *Installing the TLA Application Software on a PC* beginning on page 19.

Contact your nearest Tektronix, Inc., Service Center or Tektronix Factory Service for installation assistance.

## Upgrade Instruction Overview

The basic upgrade procedure is to manually remove the older software, update the drives, and reinstall the new software. The upgrade steps are listed in this document.

While performing the upgrade procedures, keep the following items in mind:

- Throughout this procedure you will see the term “log on as Administrator.” The instrument is set up to automatically log on as Administrator (with no password) so you may not see the log in prompt. If the network setups have been changed on your instrument, make sure that you log on as Administrator or as a user who has administrator privileges. Failure to do so can prevent the software upgrade from completing successfully.
- After logging on as administrator, quit any applications.
- If your instrument does not display the file extensions, you need to change your folder options to display the file extensions. (From the Control Panel, double-click Folder Options, select the View tab, and then deselect the “Hide file extensions for known file types” selection.)
- Use the Windows Add or Remove Programs Control Panel utility to remove existing software.
- You will be asked to restart Windows after you install each software package. If you do not restart Windows when prompted your software may not install properly and can cause unpredictable behavior.
- If Windows does not restart normally, press and hold the On/Standby button for five or six seconds to force a shutdown.
- You may be asked to remove some software packages that may not be loaded on your instrument. If this is the case, skip those instructions.

## Remove the Old Software

Complete the following steps to remove old software from your logic analyzer. Skip any steps that mention software that isn't installed on your logic analyzer.

---

**NOTE.** Refer to the release notes for a list of software version numbers to determine which software you may need to upgrade. The release notes are included on the TLA application software CD.

---

1. If you have not already done so, power on the logic analyzer and log on as Administrator.
2. Exit the TLA application.
3. Open the Control Panel.
4. Double-click the Add or Remove Programs icon.
5. For each of the following software packages, select the software (the exact names may vary depending on the software version), click the Change/Remove button, and follow the on-screen instructions to remove the software:
  - Adobe Acrobat Reader
  - CheckIt Utilities (V6.5.5)
  - Logitech Mouseware (V9.41.2 or earlier)
  - Click'N Burn Pro
  - NI-488.2
  - NI-Max
  - QA+Win32
  - SnagIt
  - Macromedia Flash Player
  - Stomp RecordNow MAX
  - Tektronix Pattern Generator
  - Tektronix TLA Application
6. Windows will uninstall the selected application. If any messages appear asking you for permission to remove unused shared files or any read-only files, select **Yes to All**.
7. After the software has been successfully removed, restart Windows.

## Update the TLA Drivers (Required for TLA Application Software V4.4 or Earlier)

Complete the following steps to remove the old PCI-VXI Bridge driver and install the new one required by the TLA. Skip this section if your TLA Application Software is V5.0 or higher.

1. After rebooting the instrument, insert the second CD of the TLA Application software set.
2. Open the Windows Control Panel.
3. Open the Device Manager in the Hardware page of the System Properties dialog box.
4. Select **PCI-VXI Bridge** from the PciVxi listing.
5. Right-click to uninstall the device and then confirm that you want to delete the device.
6. Restart the instrument.

After restarting, the instrument detects a new device and displays a dialog box.

7. Click **Cancel** to exit the dialog box.
8. Open the Device Manager in the Hardware page of the System Properties dialog box.
9. Under the PciVxi listing, Right-click **Other PCI Bridge Device** and select **Properties**.
10. Select the Driver page and click **Update Driver**.

The Upgrade Device Driver Wizard displays.

11. Click **Next**.
12. In the Install Hardware Device Drivers page, select **Search for a suitable driver for my device (recommended)** and then click **Next**.
13. In the Locate Drive Files page, select **Specify a location** and click **Next**.
14. Click Browse and go to the directory that contains the new pci2tla.inf driver file. (**D:\Drivers\your instrument\PCI-VXI Bridge\pci2tla.inf**).
15. Select the pci2tla.inf driver and then click **Open**.
16. Click **OK** to install the driver.
17. In the Driver Files Search Results page, make sure that **Install one of the other drivers** checkbox is selected and then click **Next**.

18. Select the **PCI to TLA Bridge** driver and then click **Next**.
19. Click **Finish** to complete the installation.

## Install Adobe Acrobat Reader

1. Log on as Administrator.
2. Install TLA V5.1 Application Software CD 1 in the CD drive.
3. Browse to the Documentation folder on the CD and double click **AdbeRdr70\_enu\_full.exe**.
4. Follow the on-screen instructions.
5. After the software has been successfully installed, restart Windows.

## Install Snagit

1. Log on as Administrator.
2. Browse to the Snagit folder on the CD and double-click **Setup.exe**.
3. Follow the on-screen instructions and clear the check box for starting Snagit automatically. Use the remaining default choices provided by the installer.
4. After the software has been successfully installed, restart Windows.

## Install NI-GPIB

1. Log on as Administrator.
2. Browse to the NI-GPIB-USB folder on the CD and run the Setup.exe program.
3. Follow the on-screen instructions and note the items below:
  - a. When prompted, select the Typical installation option.
  - b. When the Add GPIB wizard appears, select **GPIB-USB-B**.
  - c. After restarting the instrument, the NI-488.2 Getting Started wizard displays. This is not needed; select **Do not show at Windows startup**.
  - d. When you first connect the iView cable, the instrument will detect the new hardware. Select **Install the software automatically (Recommended)**.

## Install the TLA Software

The TLA software uses a wizard to install the following software applications (if they are not already installed) for your instrument:

- TLA Application
  - Pattern Generator Application
  - Microsoft's .NET Framework
  - OpenChoice TekVisa
  - TPI Client
  - PPI Client
1. Log on as Administrator.
  2. Browse to the TLA Application folder on the CD and double-click **Setup.exe**.
  3. Follow any on-screen instructions. If you are asked for permission to overwrite any read-only files, select **Yes to All**.
  4. After the software has been successfully installed, restart Windows.

## Install CheckIt Utilities

1. Log on as Administrator.
2. Exit the TLA application.
3. Install TLA V5.1 Application Software CD 2 in the CD drive.
4. Browse to the CheckIt folder on the CD and double-click **Start.exe**.
5. Click Next to start the installation.
6. Read and accept the license agreement.
7. When prompted for the CheckIt serial number, use U7-999999.
8. Follow any on-screen instructions and use all of the default choices provided by the installer.
9. Before clicking Finish, clear any check boxes that ask you to start the application or to view the Readme file.
10. After the software has been successfully installed, restart Windows.

## Install Flash Player

1. Log on as Administrator.
2. Exit the TLA application.
3. Browse to the Macromedia folder on the CD and double-click **flashplayer6\_winax.exe**.
4. Follow the on-screen instructions.
5. After the software has been successfully installed, restart Windows.

## Install Logitech Mouseware

1. Log on as Administrator.
2. Exit the TLA application.
3. Browse to the Mouseware folder on the CD and double-click **Setup.exe**.
4. Follow the on-screen instructions.
5. After the software has been successfully installed, restart Windows.
6. Follow the on-screen instructions in the Device Setup Wizard to set the mouse to the factory recommended settings.

## Install the Nero Suite 3 Software

The Nero OEM Suite software is available on a separate CD.

1. Log on as Administrator.
2. Exit the TLA application.
3. Insert the Nero CD into the CD drive.
4. Follow the on-screen instructions to install the software.
5. Enter the serial number when prompted (provided on the CD envelope).
6. Click Exit when done and then remove the CD.
7. Restart Windows.

## Optional Software

Tektronix offers the following service-related software for running the performance verification software.

- TLA Logic Analyzer PV
- Pattern Generator PV
- TLACAL

You should only need to install this software if you are running performance verification procedures with the appropriate test fixtures.

1. Log on as Administrator.
2. Exit the TLA application.
3. Browse to the appropriate folder on the CD and double-click **Setup.exe**.
4. Follow the on-screen instructions.
5. After the software has been successfully installed, restart Windows.

## Upgrade the Firmware

The firmware upgrade procedures depend on your logic analyzer.

### TLA7000 Series Mainframes

Complete the following steps to upgrade the instrument firmware (Refer to *TLA700 Series Logic Analyzers and Modules* on page 15 to upgrade module firmware):



---

**CAUTION.** *You MUST perform these steps to ensure that your Mainframe firmware has been upgraded. Failure to do so will result in the instrument not functioning properly and the instrument may need to be repaired at the factory.*

---

1. Log on as Administrator.
2. Exit the logic analyzer application.
3. Click Start → All Programs → Tektronix Logic Analyzer → TLA Firmware Loader.
4. Select your instrument from the Firmware Loader - Connection dialog box and click Connect.
5. Click **Load** in the *upper* portion of the Load Firmware dialog box to identify or to load mainframe firmware.

6. Compare the version numbers in the two columns. If the **Running** version does not match the **Required** version, you *MUST* upgrade the firmware.
7. In the Frame column, click the **Mainframe** name that corresponds to the firmware that requires upgrading and then click **Update Firmware**.
8. The next dialog box will have the correct .upd file selected in the file name box. Click **Open**.
9. When the next window appears, click **Start Flash Operation**. The operation may take several minutes.
10. Follow the remaining on-screen instructions.
11. Repeat the above steps for each mainframe firmware that is out of date.

### **TLA5000 Series Logic Analyzers**

1. Log on to the instrument as Administrator.
2. Exit the logic analyzer application.
3. Click Start → Programs → Tektronix Logic Analyzer → TLA Firmware Loader.
4. Select your instrument from the Firmware Loader - Connection dialog box and click Connect.
5. You may see a pop-up window reminding you to cycle the power on the instrument after completing the upgrade operation. Click Yes to continue.
6. Select the product from the Supported list box near the top of the window.
7. Select Load Firmware from the Execute menu.
8. If you have a TLA5000 Series Logic Analyzer click the TLA520x.lod file.
9. Click Open. You will be asked to confirm your action; click Yes when prompted.
10. Exit the firmware loader program and power down the logic analyzer. You must power down the logic analyzer to allow the TLA application to start up properly.



## TLA700 Series Logic Analyzers and Modules

If you need to upgrade the firmware on your logic analyzer modules, a startup message appears telling you that you need to upgrade.

1. Note the modules that require new firmware.
  - a. For TLA7Axx/TLA7NAx series logic analyzer modules skip steps 2–8 and go directly to step 9 on page 16.
  - b. For all other module types continue with step 2.
2. Turn off the logic analyzer and disconnect the power cord.
3. Remove the modules from the logic analyzer.
4. Refer to Figure 1 and locate the flash programming pins on the rear of each module.
5. Install a jumper on the flash programming pins.
6. Reinstall the module(s) in the logic analyzer.

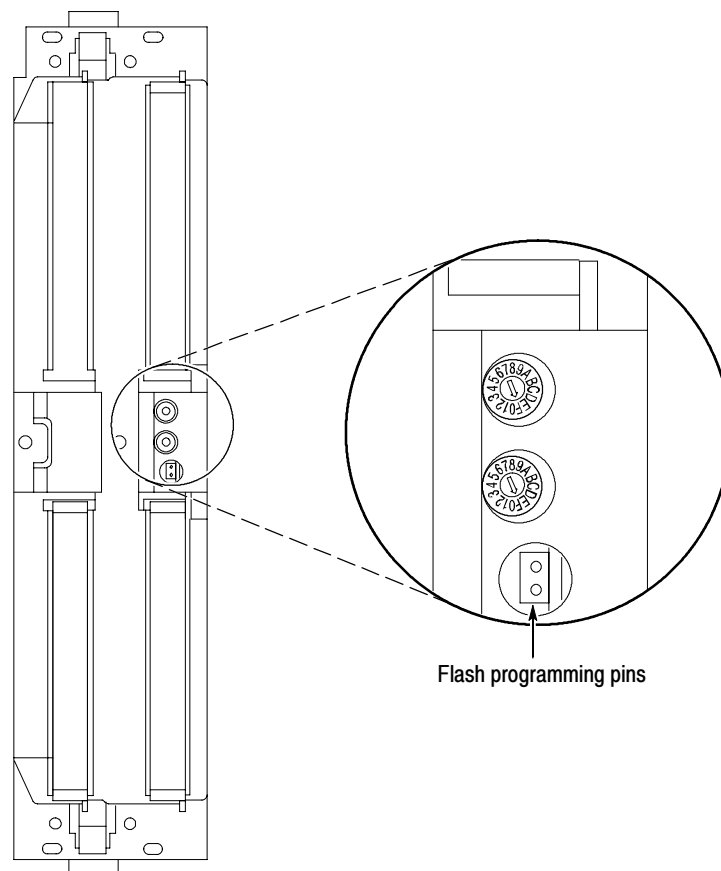

**Figure 1: Flash programming pins**

7. Reconnect the power cord and then power on the logic analyzer.
8. Log on as Administrator and then wait for the TLA application to start.

---

**NOTE.** Any modules with the flash programming jumper installed will not display in the System window.

---

9. Exit the TLA application.
10. Click Start → Programs → Tektronix Logic Analyzer → TLA Firmware Loader.
11. Select your instrument from the Firmware Loader - Connection dialog box and click Connect.
12. Select the modules that you want to update from the list of modules displayed in the Supported list box near the top of the window. This selects the modules for the upgrade. If you are upgrading more than one module at a time, note the slot location of the module in the selection box.
13. Select Load Firmware from the Execute menu.
14. Click the proper .lod file for the selected module; refer to Table 2 if necessary.

---

**NOTE.** Be sure to select the proper .lod file for each module. Note the slot number in the title bar so that you select the correct module for the .lod file.

---

**Table 2: TLA firmware files**

Module type	.lod file
TLA7NAx logic analyzer modules	TLA7NAX.lod
TLA7Axx logic analyzer modules	TLA7AXX.lod
TLA7Nx, TLA7Px, TLA7Qx logic analyzer modules	TLA7NPQ.lod
TLA7Lx and TLA7Mx logic analyzer modules	TLA7LM.lod
TLA7Dx and TLA7Ex DSO modules	FirmwareDSO.lod
TLA7PG2 Pattern Generator modules <sup>1</sup>	tla7pg2.lod

<sup>1</sup> The .lod files for the pattern generator modules are located in the C:\Program Files\Tektronix Pattern Generator\Firmware folder. All other files are located in the C:\Program files\TLA 700\Firmware folder.

15. Click OK. When prompted to confirm your action; click Yes.

---

**NOTE.** *The program will not allow you to load firmware to an incompatible module. For example, the program will not load DSO firmware to a logic analyzer module.*

---

The program will load the firmware for each module one at a time. The process may take several minutes per module.

16. When the upgrade is complete, exit the program.
17. For TLA7Axx/TLA7NAx series logic analyzer modules skip the remaining steps in this section and continue with *Verify Proper Operation* on page 17. For all other module types continue with step 18.
18. Turn off the logic analyzer and disconnect the power cord.
19. Remove the module from the instrument and remove the jumper from the Flash programming pins on the rear of the module. Keep the jumper for future updates.



---

**WARNING.** *Dangerous voltages may be present when the instrument is connected to the Target system. To avoid electrical shock, always tighten the hold-down screws that secure the module to the mainframe.*

---

20. Reinstall the module in the logic analyzer, latch it in place, and tighten the hold-down screws.
21. Reconnect the power cord and power on the instrument.
22. Verify that the power-on diagnostics pass.

## Verify Proper Operation

After you have installed all of the latest software and upgraded the module firmware, you are ready to verify operation.

1. If you have not already done so, power on the logic analyzer and log on as Administrator.
2. Verify that the Power-on diagnostics pass (if any Power-on diagnostics fail, the Power-on Diagnostics dialog box automatically displays in the System window).
3. In the System window, verify that all installed modules appear in the window.

4. If you have a TLA7000 series or TLA700 series instrument with any missing modules in the System window, you can verify the status of the modules by doing the following steps:
  - a. Select System Properties in the System menu.
  - b. Click the Modules tab.
  - c. Note the information under the Messages column for any installed modules. If any modules indicate invalid or similar messages, you must update the firmware for those modules. (See *Upgrade the Firmware* on page 13).
  - d. If any of the modules indicate that the jumper is installed, power down the logic analyzer, remove the module, and then remove the jumper from the rear of the module. Reinstall the module in the instrument and try again.

## Calibrate the Logic Analyzer and DSO Modules

After verifying proper operation it is recommended that you calibrate the logic analyzer and DSO modules if they are installed in your instrument (pattern generator modules do not require calibration).

1. Allow the instrument to warm up for at least 30 minutes before continuing.
2. In the System window, select Calibration and Diagnostics from the System menu.
3. Click the Self Calibration tab.
4. Select all of the modules in the dialog box and Click Run.

---

**NOTE.** *The calibration process may take several minutes for each module.*

---

5. Verify that the Status column for each module changes to Calibrated.
6. After all of the modules have been calibrated close the dialog box and power down the instrument.

## Installing the TLA Application Software on a PC

You can install the TLA application software on a PC for the following purposes:

- To run the TLA application software in the Offline mode (similar to TLAVu in earlier software versions).
- To control a logic analyzer with the same TLA application software version over a network.

### Install Third-Party Software

To use all of the features of the TLA application software on your PC, you must install additional third-party software. The following third-party software is available on the TLA Application Software CD V5.1, or higher:

- The NI-GPIB-USB software allows you to use the iView software with your PC.
- The SnagIt software is useful for copying screen shots of logic analyzer data for use with other applications.

---

**NOTE.** Several third-party software applications are included to use with your logic analyzer. These applications may include software license agreements. Be sure to abide by those license agreements.

---

**Install the NI-GPIB Software.** Complete the following steps to install the NI-GPIB software on your PC:

1. Install the TLA Application Software CD in the CD drive.
2. Browse to the NI-GPIB-USB folder on the CD and run the Setup.exe program.
3. Follow the on-screen instructions and note the items below:
  - a. When prompted, select the Typical installation option.
  - b. When the Add GPIB wizard appears, select **GPIB-USB-HS**.
  - c. After restarting the instrument, the NI-488.2 Getting Started wizard displays. This is not needed; select **Do not show at Windows startup**.
  - d. When you first connect the iView cable, the instrument will detect the new hardware. Select **Install the software automatically (Recommended)**.

**Install the SnagIt Software.** Complete the following steps to install the SnagIt software on your PC:

1. Install the TLA Application Software CD in the CD drive.
2. Browse to the SnagIt folder on the CD and run the Setup.exe program.
3. Follow the on-screen instructions.

### **Install the TLA Application Software**

Browse to the TLA Application software folder on the CD and run the Setup.exe program. Follow the on-screen instructions to install the TLA application software.

If you have an older version of the software on the hard disk, the installation program will detect it and ask if you want to remove it. Follow the on-screen instructions to remove the software, answering “Yes” to any prompts. Restart the instrument when prompted and run the Setup.exe program again.

### **Start the TLA Application**

If you have installed the TLA application software on a PC for remote operation, start the software by double-clicking on the TLA Application icon. The TLA Connection dialog box displays.

1. Select an instrument in the TLA Connection dialog box and then click **Connect**. If your instrument is connected to a network, you can connect to any unused instrument on your network.
2. Click **Offline** to start an offline version of the TLA application software. The TLA Offline software allows you to run the TLA application without connecting to an instrument. You can analyze previously acquired data from a logic analyzer, create or modify reference memories, or perform system tests without being connected to an instrument.

## **Attach the Upgrade Kit Label**

After completing all the previous steps, you need to install the upgrade kit label to individual modules and on the instrument to indicate that the kit is installed.

---

**NOTE.** *If there already is an upgrade kit label installed, install the new label just above or below the old one. However, ensure that you install the software revision label over the old revision label to indicate the current version of software or firmware on your instrument.*

---

**TLA5000 Series Instruments**

Locate the big label on the rear of the instrument, and then attach the software revision label and the kit label as shown in Figure 2.

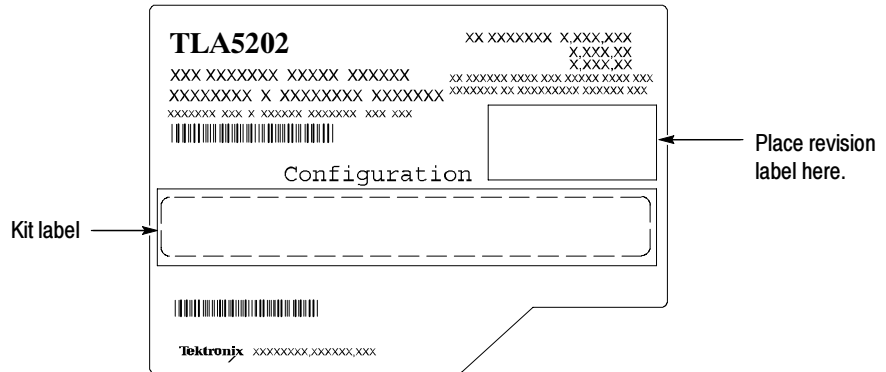

**Figure 2: TLA5000 revision and kit label locations**

**TLA700 or TLA7000 Portable Mainframes**

Locate the big label on the bottom of the instrument, and then attach the software revision label and the kit label as shown in Figure 3.

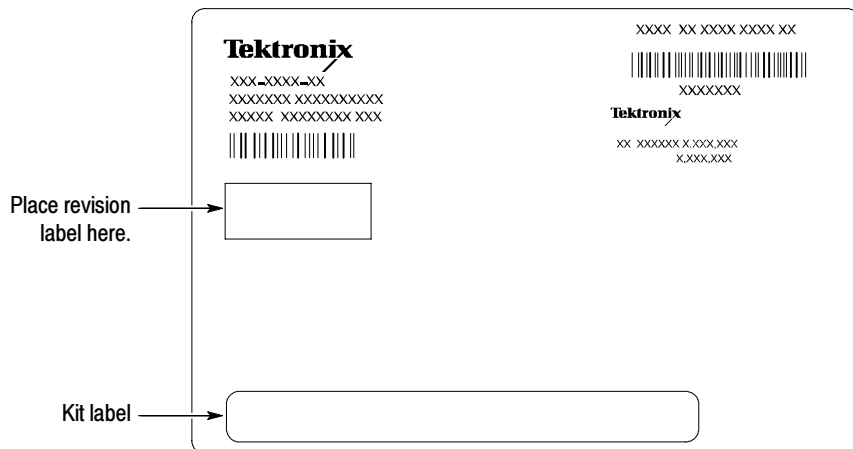

**Figure 3: TLA700 or TLA7000 revision and kit label locations**

**Benchtop Mainframes and Instrument Modules**

On the Benchtop Mainframes and instrument modules, the software label is located on the side of the controller or module. You must remove the modules from the mainframe before you can install the software revision label.



**CAUTION.** To avoid damaging the mainframe or the modules, always power down the mainframe before removing any modules.

---

1. Power down the mainframe.
2. Loosen the four hold-down screws that secure the front of the module to the mainframe.
3. Remove the module from the mainframe and set it on a clean working surface.
4. Locate the big label on the side of the module and attach the software revision label and the kit label as shown in Figure 4. Repeat the process for each instrument module where you updated the firmware.

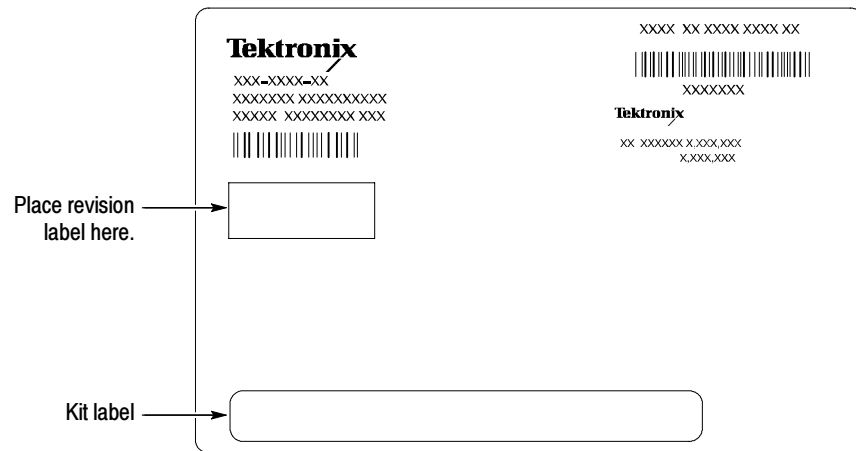

**Figure 4: TLA700 or TLA7000 revision and kit label locations**



**WARNING.** Dangerous voltages may be present when the instrument is connected to the Target system. To avoid electrical shock, always tighten the hold-down screws that secure the module to the mainframe.

---

5. Reinstall the modules in the benchtop mainframe, tighten the hold-down screws.
6. Power on the mainframe and verify that all diagnostics pass.

■ End of document ■